



Product Catalogue
PMR &
Critical Communications

PANORAMA  ANTENNAS

70 Years of Experience

Panorama Antennas is a family business now in its third generation and a leading designer and manufacturer of antennas for radio communication. Established in London in 1947, Panorama started life as a company manufacturing consumer products. In 1952, buoyed by huge demand for TVs in the UK, Panorama began manufacturing components for televisions, including antennas. With the transistor radio trend of the 1960s, Panorama's expert knowledge of television antennas was put to the manufacture of communication antennas for radio.

Throughout the 70s and 80s, Panorama evolved to become the first specialised communication antenna manufacturer in the UK, developing a range of cellular antennas to coincide with the launch of the mobile phone network in Britain. In 1990, Panorama filed a patent application for the first ever solid state coupling circuit, revolutionising cellular glass mount antenna technology and creating a new benchmark for quality in the production of components. As the cellular telecommunications industry has grown worldwide, so has Panorama.

Today Panorama produces antennas for the world's leading communication companies. While Panorama has grown to include 8 international offices, 2 subsidiaries, and over 70 staff; manufacturing, design and development are retained in London less than a mile from the original factory. Our network of international sales representatives means that all customers get the attention and advice they require, providing local support on global scale.

Antennas For Next Generation Technology

Panorama's constant cutting-edge research ensures that our antennas meet the demands of the very latest public safety communications technology. Trusted by thousands of professionals the world over, our antennas are depended on to provide critical communications even in the most challenging conditions.

With 70 years experience in delivering world-class antenna products, Panorama's current product range reflects our unparalleled expertise in providing high-quality performance antennas.



Contents

- 6** Multifunction Antennas
- 12** GPS Antennas
- 13** Special Application Antennas
- 22** Mobile Router Cellular Antennas
- 24** Mobile Router WiFi Antennas
- 28** Covert Antennas
- 32** InBuilding Antennas
- 38** Modular Bases
- 41** Modular Whips
- 45** Combination Base Whips
- 49** Accessories
- 58** Portable Antennas
- 59** Cables & Connectors



Catalogue Key

Products within this catalogue feature symbols to identify their potential uses and particular attributes. This guide will assist in identifying each symbol, and help clarify a product's full specification.



iBwave

Products with this icon are profiled in the iBwave component database for wireless network planning.



PiMGuard

PiMGuard products have been designed to give protection from passive intermodulation, thereby increasing network efficiency.



SAR Approved

SAR approved antennas have been tested by an approved test house according to EN 50385:2002 and test data is available for Input Power levels meeting Specific Absorption Rate requirements.



Ingress Protection Rating

This denotes the antenna's IP rating, and its subsequent resistance to dirt, water and pressure.



Ground Plane Independent

Antennas with this symbol are ground plane independent and as such do not need a ground plane to operate.



MiMo

Meaning 'Multiple Input Multiple Output, antennas with this symbol have two or more inputs and outputs of a particular feed.



GPS Satellite Navigation

Our GPS antennas feature a high-performance GPS element that provides reliable signal, utilising GPS, GLONASS, Galileo and BeiDou.



InBuilding

These antennas are designed to be used on or inside buildings in order to provide network coverage.



Public Safety

Ideal for use in critical communication environment, these antennas are available for a range of frequencies and applications.



Transport

These specialist antennas are developed to exacting standards in order to withstand the toughest conditions on or in a vehicle.



Utility

For creating and extending a network service in challenging environments, these utility antennas are reliable and high-performance.



Quality As Standard

Quality Assurance

In 1989, Panorama Antennas became the first antenna manufacturer in Europe to gain ISO 9000 certification. Panorama currently holds the ISO 9001-2008 certificate for quality assurance.

Patents

Panorama Antennas currently holds several patents and registered designs both in Europe and worldwide.

RoHS Compliance

All of the products that Panorama Antennas manufactures are 100% RoHS compliant. This is in line with European legislation which came into force on the 1st July 2006. Investment in advanced technology enables Panorama to test materials supplied to us as soon as they arrive at the factory, ensuring that noncompliant material is not passed on to the customer.

REACH

REACH (Registration, Evaluation, Authorisation and Restriction of Chemicals, EC 1907/2007) is the European Union's chemical regulation that came into force on 1 June 2007 and will be phased in over an 11 year period (until 2018). Panorama Antennas wholeheartedly supports the objective of REACH to enhance public health and safety and the protection of the environment. Panorama is committed to meeting REACH requirements and can provide information about substances in accordance with the requirements.

Associations

Panorama Antennas is currently a member of the following professional associations:

-  *Federation of Communication Services*
-  *TCCA TETRA Association*
-  *British Safety Council*
-  *British APCO*





The 'Great White' Range

Low profile antenna with up to 6 functions in 1
 Optional integrated GPS antenna (LGMM range)
 Up to 4 x 2.4 & 4.9-6GHz WiFi/WiMAX elements
 Various mounting options available

Ground Plane Independent

This antenna does not require a ground plane, and maintains a high level of performance even when mounted on a non-metallic surface.

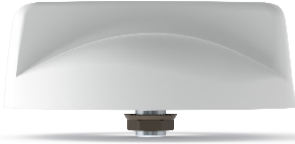

Standard Data

Electrical Data	
Frequency Range (MHz)	698-960, 1700-2700 (Cellular) 2400, 4900-6000 (WiFi / WLAN), 1575 (GPS)
Peak Gain: Isotropic	2.3dBi (698-960), 5dBi (1700-2700), 2dBi (2400/4900-6000)
Typical VSWR	< 2.5:1 (Cellular) < 2:1 (WiFi/WLAN)
Isolation with 5m CS29	4G/LTE >12dB WiFi >20dB
Correlation Coefficient	<0.2
Mechanical Data	
Dimensions (mm)	Height 62 (2.4")
	Diameter 176 (6.7")
Material	ASA & diecast aluminium
Mounting type	Panel Mount (standard) / Ribbed Roof Adaptor (LGMM-EXT), Magnetic Mount (SAB-225), Trunk Mount Kit (SAB-207)
Ingress Protection	IP66 (EN 60529:1992)

The robust, low profile antenna housing contains two wideband elements covering 698-2700MHz to support 2x2 MiMo function for 4G/LTE with fall back to 3G/2G. It can also be supplied with two, three or four dual band 2.4/5.0GHz elements to support MiMo function for WiFi or WiMAX. Both antenna functions feature high isolation and low correlation coefficient value for effective MiMo operation in a compact form factor.

The LGMM[B] version includes an active GPS antenna with 25dB gain LNA and high performance filtering.

- Black
- White

Variants

	GPS	MiMo LTE (2x2)	MiMo WLAN (2x2)	MiMo WLAN (3x3)	MiMo WLAN (4x)
LPMM[B]-7-27		●			
LPMM[B]-7-27-24-58		●	●		
LGMM[B]-7-27	●	●			
LGMM[B]-7-27-24-58	●	●	●		
LGMTM[B]-7-27-24-58	●	●		●	
LGMMQ[B]-7-27-24-58	●	●			●

Accessories



GPSD MiMo Sharkee™

2x2 MiMo Cell, GPS/GNSS, up to 3x3 WiFi

Shark fin housing

A single antenna means faster installation and decommission

Mounting boss for optional external whip



The GPSD range offers 2x2 MiMo antennas for 698-960/1710-2700MHz with active GPS/GLONASS (26dB LNA) and optional 2x2 or 3x3 MiMo WiFi 2.4/5.0GHz.

With a built in whip mounting boss the GPSD can also support a range of Panorama Antennas' whips.

Requiring only a single hole fixing, the GPSD reduces vehicle damage, visual impact and cost of installation, whilst protecting vehicle resale value.



GLONASS

The GPSD features a GPS antenna that also supports GLONASS.



Variants

	GPS	MiMo LTE (2x2)	MiMo WLAN (2x2)	MiMo WLAN (3x3)
GPSD-7-27	●	●		
GPSD-7-27-24-58	●	●	●	
GPSDC-7-27-24-58	●	●		●

Accessories



Magnetic Mount
SAB-224

Whips - various frequencies
See range from page 41.



Standard Data

Part No.	GPSD (configure whip separately)	
Frequency Range (MHz)	698-960, 1700-2700 (2 x Cellular) 2300-2500, 4900-5000 (2 x WiFi - optional) + Optional Whip	
Operational Bands	1562-1612 (GPS/GNSS) GPS / LTE / Cellular, WiFi / WiMAX	
Max. Input Power	50 watts	
Isolation with 5m CS29	4G/LTE >12dB WiFi >20dB	
Correlation Coefficient	<0.2	
Mechanical Data		
Dimensions (mm)	Height	50 (1.97")
	Length	170 (6.69")
	Width	60 (2.36")
Material	ASA	
Mounting type	Panel mount	

'The Sharkee™' Combination Antenna



All 4G, 3G & 2G cellular bands
 Integrated GPS and 2.4/4.9-6GHz WiFi & WiMAX
 Optional VHF / UHF whip element

The GPSB provides antenna functions for multiple technologies within one antenna housing. Trusted by public safety organisations, utilities and transportation companies all over the world, the GPSB sets the industry standard in functionality.

The GPSB offers three internal antenna systems, GPS, 4G/3G/2G cellular, dual-band WiFi/WiMAX as well as an optional external whip mount.

Requiring only a single hole fixing, the GPSB reduces vehicle damage, visual impact and cost of installation, whilst protecting vehicle resale value.

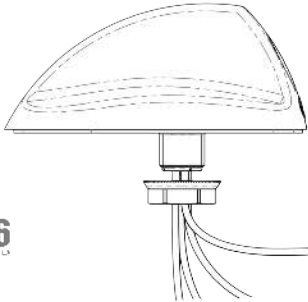

Accessories

Whips - various frequencies
 See range from page 41.



Standard Data

Part No.		GPSB (configure whip separately)
Frequency Range (MHz)		698-960, 1710-2170, 2500-2700 (Cellular), 2400, 4900-6000 (WLAN / WiFi) + Optional Whip 1575 (GPS)
Peak gain: Isotropic		1dBi (Cellular), 2dBi (WLAN/WiFi) 26dB (GPS)
Pattern		Omni-directional
Mechanical Data		
Dimensions (mm)	Height	50 (2")
	Length	120 (4.72")
	Width	58 (2.3")
Ingress Protection		IP66



Configure Your Whip & Cable

Turn to page 59 to select a cable set and connectors for this product. To select a whip suitable for this combination base, please turn to pages 41-48.

Combination GPS/Whip

- Combined GPS and VHF, UHF or cellular whips
- Integrated GPS/GLONASS antenna
- Best seller
- Optional magnetic mount



The GPSGK and GPSKM combi bases provide dual function with an active GPS antenna with 26dB gain LNA and high performance filtering. The GPSGK version is compatible with GPS, GLONASS & BeiDou systems.

The bases are provided with a mounting stud compatible with a wide range of Panorama whips for VHF, UHF, TETRA and 800MHz. The base has a single M14 mounting bolt and can be fitted to a mounting panel with up to 6mm thickness. An optional extender kit is available for thicker mounting panels.

The dual function with rapid installation in a single hole has made this range a popular choice for Public Safety, Utility and Transportation organisations.



GLONASS

The GPSGK is compatible with GLONASS navigation system.

Accessories

Whips -various frequencies
See range from page 41.

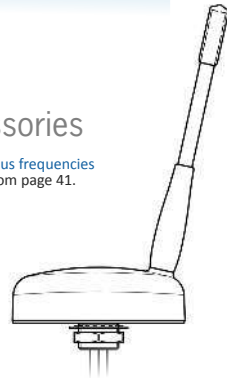

Variants

Part No.	Frequency (MHz)	Mount Type	Certification
GPSGK-FF	1575-1610 (GLONASS)	Panel Mount	-
GPSKM	1575	Magnetic Mount	E11 'E-Mark'

Standard Data

Electrical Data		
Peak Gain: LNA	26dB	
Operating Voltage	3 - 5V DC (fed via coax)	
Current	Typical 15mA	
Mechanical Data		
Dimensions (mm)	Base Width	50 (2.0")
	Base Height	18.5 (0.7")
Operating Temp (°C)	-40°/+80°C (-40°/+176°F)	
Material	High Impact U.V. Stable A.B.S	
Ingress Protection	IP65	



Configure Your Whip & Cable

Turn to page 59 to select a cable set and connectors for this product. To select a whip suitable for this combination base, please turn to pages 41-48.

'The Stingray' Combination Antenna



- Dashboard or windshield mount
- Supports LTE 4G/3G/2G & WiFi 2.4/5.0GHz
- Suitable for M3 category vehicles (UNECE Reg 118)
- Available with SMA or FAKRA connectors



GPS



Public Safety



Transport



Utility



GLONASS

The GPSCO features a GPS antenna that also supports GLONASS.

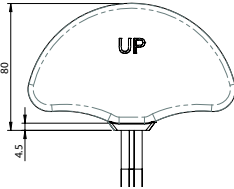

The GPSCO[F]-7-27-24-58 range of antennas offer a "3 in 1" solution ideal for telematics or other vehicle communications, where the antenna needs to be fitted discretely or for a "no hole" installation. The compact housing incorporates antennas for Cellular/LTE, Dual Band WiFi and GPS/GLONASS/BEIDOU with a 26dB gain LNA and high performance filtering.

Meeting the requirements of UNECE Regulation R 118, the antenna is suitable for use in M3 Category vehicles (Transportation). The antenna housing is UV resistant and flame retardant, while the 3m length integrated coax cables are flame retardant, low smoke specification.

The antenna offers easy and quick installation on/under the dashboard or on the windshield using the supplied acrylic adhesive pad.

Variants

	GPS	LTE	WiFi	MIMO WiFi (2x2)
GPSCO[F]-7-27-24-58		●	●	
RAYM2-24-58	●	●		●

Standard Data

Part No.		GPSCO-7-27-24-58
Frequency Range (MHz)		698-960, 1700-3800 (Cellular), 2400, 4900-6000 (WLAN / WiFi) 1562-1612 (GPS)
Peak gain: Isotropic		1.5dBi (890-960), 4.5dBi (1710-2170) 4.5dBi (2500-3800), 6dBi (2.4GHz), 7dBi (4.9-6.0GHz)
Pattern		Omni-directional
Max Input Power (W)		20
Mechanical Data		
Dimensions (mm)	Height	80 (3.5")
	Width	131 (5.16")
	Depth	15 (0.6")
Ingress Protection		IP66

'The Fez' Combination Antenna

- Ground plane independent
- Wideband LTE/cellular element
- 2.4 & 4.9-6 GHz WiFi/WiMAX element (Optional)
- Integrated GPS antenna (Optional)

The LP(G)E antenna series is a range of low profile combination antennas. The basic version includes a single wide band cellular element for 698-2700MHz for 4G/3G/2G application. A version that adds either a single or 2x2 MiMo 2.4/5.8GHz antenna is available, and both can be supplied as LG type which incorporates an active GPS/GNSS antenna with 26dB gain LNA and high performance filtering.

Developed as a tough, cost effective antenna, the "Fez" features an IP66 rated, weather and impact resistant moulded ASA cover. The antenna is supplied with short fly leads and can be kitted with Panorama low loss extension coax cables for a simple plug and play installation.



Ground Plane Independent

This antenna does not require a ground plane, and maintains a high level of performance even when mounted on a non-metallic surface.



Standard Data

Part No.	
Frequency Range (MHz)	698-960, 1700-2700 (Cellular), 2300-2500, 4900-6000 (WiFi), 1575 (GPS)
Operational Bands	GPS / LTE / Cellular, WiFi / WiMAX
Peak Gain: Isotropic	2dBi
Max Input Power	50 watts
Mechanical Data	
Dimensions (mm)	Height 70 (2.8" in)
	Diameter 111 (4.4" in)
Material	ASA
Mounting type	Panel mount
Ingress Protection	IP66

Variants

	GPS	LTE	WLAN	MiMo WLAN (2x2)
LPE-7-27		●		
LGE-7-27	●	●		
LGE-7-27-24-58	●	●	●	
LGEM-7-27-24-58	●	●		●



Select Your Cables

Turn to page 59 to select a cable set and connectors for this product. Panorama's wide range of adaptor cables means that it's simple to get the right termination for any antenna application.

GPS / GNSS Antennas



- Excellent performance
- Active GPS element
- Easy installation

Vehicle positioning is an intrinsic part of vehicle and fleet management and is achieved by use of GPS/GNSS technology. An effective antenna is required to provide reliable and consistent functionality and all Panorama GPS/GNSS antennas feature a 26dB gain LNA and high performance filtering for reliable operation.

The GPSP offers a permanent, panel mounted option, While the GPSME provides the convenience and flexibility of a temporary, no holes solution with a tough magnetic fixing.

The GPSSV type is ideal for covert installation and is supplied with both adhesive and hook/loop pad fixings. A 3m coax cable is supplied as standard, but a version with a 30cm fly lead is available which can be used with an extension coax cable where required.



GLONASS

The GPSME, GPSP and GPSSV models are available in GLONASS compatible versions upon request.

Standard Data

Part No.		GPSME	GPSP	GPSSV
Frequency Range (MHz)			1575	
VSWR			<1.5:1 @ 1575MHz ± 4MHz	
LNA Peak Gain			26dB	
Operating Voltage			3 - 5V DC (fed via coax)	
Current (Typical)			15mA	
Impedance			50Ω	
Mechanical Data				
Dimensions (mm)	Length	48.6 (1.9")	60 (2.4")	34.6 (1.36")
	Width	39.2 (1.5")	50 (2.0")	34.6 (1.36")
	Height	15.6 (0.6")	18.5 (0.7")	13.2 (0.5")
Fixing		Magnetic Mount	Panel Mount	Adhesive pad/hook & loop
Mounting Hole Diameter (mm)		-	15 (0.6")	-
Certification		-	E11 'E-Mark' Approved	E11 'E-Mark' Approved
Termination Data				
Type			RG174	
Terminations Available			FME/MCX/MMCX/SMA/SMB/SMC	

Low Profile Antenna

Rugged design for heavy duty applications
Easy installation
Ground plane Independent

The Panorama low profile antenna range has been designed to perform under extreme pressure. The outer housing is designed to withstand high impacts while maintaining its functionality.

An excellent solution for demanding applications in transportation.



Available Colours:

- Black
- White

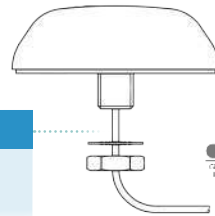

Ground Plane Independent

This antenna does not require a ground plane, and maintains a high level of performance even when mounted on a non-metallic surface.



GPI IP65
RATED

Variants

Non-GPS

Part No.	Freq. (MHz)
LP390	380-400
LP420	410-430
LP440	430-450
LP460	450-470
LPL-S5	806-870

GPS Variant

Part No.	Freq. (MHz)
LG390	380-400
LG420	410-430
LG440	430-450
LG460	450-470
LGL-S5	806-870

Standard Data

Electrical Data	
Peak Gain	0dBi
Impedance	50Ω
Max Input Power (W)	20
GPS Data	
Frequency (MHz)	1575
Gain: LNA	26dBi
Operating Voltage	3-5V DC (fed via coax)
Mechanical Data	
Certification	E11 'E-Mark' Approved
Operating Temp (°C)	-40°/+80°C (-40°/176°F)
Material	ASA
Ingress Protection	IP65



Configure Your Cable

Turn to page 59 to select a cable set and connectors for this product. Panorama's wide range of adaptor cables means that it's simple to get the right termination for any antenna application.

Glass Mount Antenna

- Excellent performance
- Solid state coupling (UHF versions)
- No hole installation

The Panorama Glass Mount Antenna can be quickly and easily installed on a windscreen or rear window without making any holes or using any tools. The installed antenna will have a typical VSWR of 1:5:1.

The antenna couples capacitively through glass and its high positioning gives it the high performance and near omni-directional radiating pattern of a roof-mounted $\frac{1}{4}$ wave.

This antenna can be easily removed for the car wash and if you wish to transfer the assembly to another vehicle, the coupling box and mounting foot can be removed without damage, leaving the glass in its original state.



Public Safety



Transport



Utility

IP65
RATED



Standard Data

Electrical Data		
Peak Gain: Isotropic	2dBi	
Max Input Power (W)	20	
Mechanical Data		
Fixing	External glass mount	
Mounting Foot Dimensions	Length (mm)	50.4 (2")
	Width (mm)	51.4 (2.1")
Ingress Protection	IP65	
Cable Data		
Cable Type	CS23	
Diameter (mm)	5 (0.2")	
Length (m)	5 (15')	

Variants

Part No.	Freq. (MHz)
AOG143	138-148
AOG151	142-160
AOG161	156-174
GM390	380-400
GM420	410-430
GM435	425-455
GM455	445-470
GM-S4	450-470
GMG-S5	806-870

½ Wave UHF Antenna

- Ground plane independent antenna
- Flexible whip
- Moulded coaxial cable
- Suitable for vehicles or fixed site applications

The HM range of antennas are ground plane independent and can therefore be mounted on any surface. The antenna is ideal for motorcycles but can also be used on other vehicles, boats or fixed sites.

The HM antenna range has a rugged design with a flexible nylon covered whip. The base features a moulded cable entry and an M14 mounting bolt.

HM Whip

This antenna can be purchased without the base - please ask for more details



Variants

Part No.	Freq. (MHz)	Part No.	Freq. (MHz)
HM-S1	380-400	HM-S4	450-470
HM-S2	410-430	HM-480	470-490
HM-TET	380-430	HM-495	480-510
HM-433	430-440	HM-S5	806-870
HM-451	438-472	HM-D	896-960

Standard Data

Electrical Data	
Peak Gain: Isotropic	4dBi
Impedance	50Ω
Max Input Power (W)	5 (20 for some variants)
Mechanical Data	
Material	Nylon
Base Diameter (mm)	35 (1.4")
Fixing	Panel mount
Mounting hole diameter	15 (0.6")
Cable Data	
Cable	CS23 (RG58 C/U)
Terminations Available	BNC / TNC / FME / Bare End

UHF Marine Antenna

- Ratchet or deck mount option
- Various UHF frequencies
- Constructed from marine grade materials
- Optional GPS element

Panorama has developed a range of marine antennas to meet the increasing demand for coverage at sea.

This antenna can be supplied as a stand alone UHF antenna or a GPS/UHF combination type with a 26dB gain low noise GPS antenna, offering a simpler and quicker installation for the customer.

This antenna will fit the standard 1"x14TPI marine mounting systems, Panorama offers both deck and ratchet mount solutions. We can also supply custom extension coaxial cable sets to meet the customer's specific installation requirements

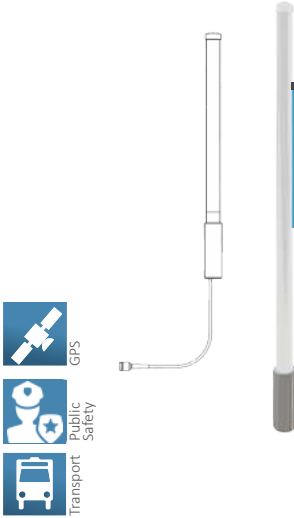

Variants

GPS Versions

Part No.	Freq. (MHz)
NA-S1-GPS	380-400
NA-S2-GPS	410-430
NA-440-GPS	430-450
NA-S4-GPS	450-470
NA-S5-GPS	806-870

Non-GPS Versions

Part No.	Freq. (MHz)
NA-S1	380-400
NA-S2	410-430
NA-440	430-450
NA-S4	450-470
NA-S5	806-870

Ratchet Mount NDRS-SL

Constructed from polished stainless steel, Panorama's NDRS-SL Ratchet Mount is designed to endure the harshest marine environments.



Electrical Data		
Peak Gain: Isotropic	5dBi	
Pattern	Omni-directional	
Max Input Power (W)	25	
Mechanical Data		
Dimensions (mm)	Length	620 (24.4")
	Diameter	30 (1.2")
Material	Fibre glass & stainless steel	
GPS Data		
Frequency Range (MHz)	1575	
GPS Gain	25dB	

Heavy Duty Transit Antenna

- Standard four hole rail fixing
- Wideband element
- Optional Integrated GPS / GNSS element
- Fully rail industry approved



The TRNC(G) antenna series has been designed specifically for use on trains, trams and buses underground or over ground.

The TRNC(G)-7-60 range covers 698-960/1710-6000MHz and the TRNC(G)-TET range covers 380-430MHz UHF. Both versions are available with an optional GPS/GNSS element with a 26dB LNA. The radiating element is DC grounded and, in versions with a GPS module it is protected by a gas discharge surge arrester.

Housed in a high impact, flame retardant Ultem housing, the TRNC(G) series is weatherproof ensuring that the antenna's performance is never compromised.

Variants

Part No.	Freq. (MHz)	GPS
TRNC-7-60	698-960/1710-6000	
TRNCG-7-60	698-960/1710-6000	•
TRNC-TET	380-430	
TRNCG-TET	380-430	•



Standard Data

Electrical Data		
Peak gain: Isotropic	5dBi	
Pattern	Omni-directional	
Max Input Power (W)	60	
Mechanical Data		
Dimensions (mm)	Height	110(4.3")
	Width	87 (3.4")
	Length	260 (10.2")
Radome Material	Ultem 1000	
Base Material	Cast Aluminium	
Mounting Type	4 x mounting holes to suit M12 bolts	
Operating Temperature (°C)	-40 / +80°C (-40° / +176°F)	
Radome Flame Retardance	V0 (UL94)	
Termination Data		
Comms	N (female) - DC grounded	
GPS	TNC (female) - surge protected	
Approval Certificates	EN50155:2007 / EN61373:2010 / EN45545:2013	

Magnetic Mount Base



- Temporary fit
- Easy removal
- Strong magnetic retention

The MD range of antennas is a popular choice for public safety vehicles that require a temporarily fixed antenna. It is also ideal for leased vehicles.

The tough magnetic base will retain the antenna to the roof or boot but will leave no evidence it was ever there once repositioned or removed.

Available in all standard VHF and UHF bands, as well as customer-specific frequencies.



Variants

Part No.	Freq. (MHz)	Part No.	Freq. (MHz)
MD146-5	141-151	MD420-5	410-430
MD-161-5	156-164	MD-TET-5	380-430
MD168-5	162-174	MD-451-5	430-472
MD390-5	380-400	MD-S5-5	806-870

Standard Data

Electrical Data	
Peak Gain: Isotropic	2dBi
Compared to ¼ wave	0dB
Bandwidth @ 2:1 VSWR	10%
Polarisation	Vertical
Pattern	Omni-directional
Impedance	50Ω
Max Input Power (W)	50
Mechanical Data	
Operating Temp (°C)	-40° / +80°C (-40° / 176°F)
Colour	Black

UHF / VHF Elevated Antenna

Mast mount

VHF, UHF and multiband versions

Ideal for fixed radio terminal applications

Quick assembly

Panorama elevated antennas can be used for temporary field use or permanent installations. The range uses flexible helical elements to provide an effective but compact groundplane. The antenna's centre fitting has a metal body to carry the radials and a moulded insulator for the radiator. The whip element is plastic coated for weather proofing and durability.



iBwave



Public
Safety



Utility

Variants

VHF Versions

Part No.	Freq. (MHz)	Peak Gain: Isotropic
BSV-E3	67-74	2dBi
BSV-E4	74-81	2dBi
BSV-E5	81-88	2dBi
BSV-H3	132-143	2dBi
BSV-H4	141-151	2dBi
BSV-H5	149-159	2dBi
BSV-H6	156-162	2dBi
BSV-H7	162-174	2dBi

UHF Versions

Part No.	Freq. (MHz)	Peak Gain: Isotropic
BSU-TET	380-430	2dBi
BSU-TETG5	380-430	5dBi
BSU-UT	406-472	2dBi
BSU-U	430-472	2dBi
BSU-S4	450-470	2dBi
BSU-W	470-512	2dBi
BS800	804-870	5dBi

Tri-band Versions

Part No.	Frequencies (MHz)	Peak Gain: Isotropic
BSV-155-S4-821	145-174/420-480/764-894	2dBi
BSV-155-U1-B1	150-160/410-470/746-806	2dBi
BSV-155-U1-S1	150-160/410-470/806-870	2dBi

Standard Data

Electrical Data	
Peak Gain: Isotropic	2dBi
Pattern	Omni-directional
Max Input Power (W)	100
Mounting Data	
Max mast diameter (mm)	50 (1.97")
Connector	'N' Socket

Rapid Deployment Clip Dipole (CDV/CDU Series)

- Rugged construction
- Fast installation
- Moulded in coaxial cable

The 'Clip Dipole' range is designed for quick and easy assembly and installation on remote sites. It is used by the police and ambulance services when operating from remote venues, such as a public event or sports event.

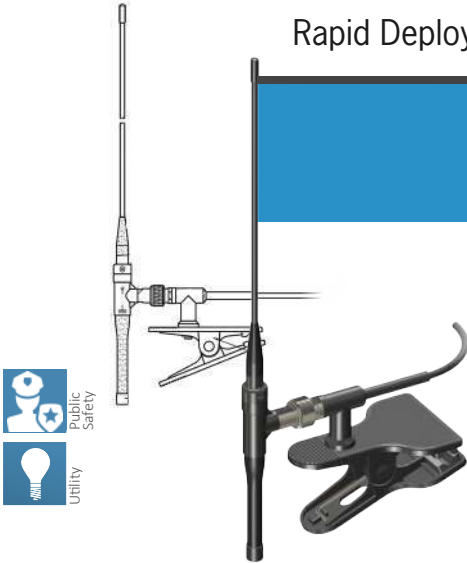

Variants

Part No.	Freq. (MHz)	Part No.	Freq. (MHz)	Part No.	Freq. (MHz)	Part No.	Freq. (MHz)
CDV-E3	67-74	CDV-H5	149-159	CDV-M	245-275	CDU-TET	380-430
CDV-E4	74-81	CDV-H6	156-162	CDV-N	270-300	CDU-U1	410-470
CDV-E5	81-88	CDV-H7	162-174	CDV-P	300-336	CDU-T2	420-456
CDV-H3	132-143	CDV-K5	174-192	CDV-R	330-366	CDU-U	430-472
CDV-JRC	139-157	CDV-K6	192-208	CDU-S1	380-400	CDU-U2	450-512
CDV-H4	141-151	CDV-K7	208-225	CDU-S2	410-430		

Electrical Data

Peak Gain: Isotropic	2dBi
Compared to ¼ wave	0dB
VSWR	<2.2:1
Polarisation	Vertical
Pattern	Omni-directional
Impedance	50Ω
Max Input Power (W)	50

Mechanical Data

Operating Temp (°C)	-40°/+80°C (-40°/176°F)
Colour	Black

Rapid Deployment ½ Wave (CD Series)

Groundplane independent antenna
Fast 'clip on' installation
Moulded coaxial cable

The performance and scope of portable equipment can often be considerably improved by elevating the antenna to a more effective height. Clip antennas provide an easy way to do this. The CD series features a rugged single end fed ½ wave element.

The jaws of the spring clip are moulded in nylon and are fully adjustable for any angle. The clip mount features a fully moulded coaxial connection for weather protection and resilience.

Variants

Part No.	Freq. (MHz)
CD390	380-400
CD420	410-430
CD433	430-450
CD458	445-470
CD800	806-870
CD900	870-960

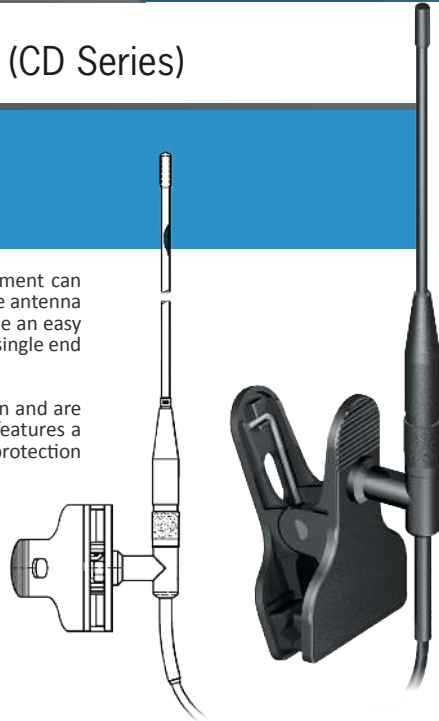

Standard Data

Electrical Data	
Peak Gain: Isotropic	3dBi
Compared to ¼ wave	1dB
VSWR	<2.2:1
Polarisation	Vertical
Pattern	Omn-directional
Impedance	50Ω
Max Input Power (W)	5 (20 for some variants)
Mechanical Data	
Operating Temp (°C)	-40° / +80°C (-40° / +176°F)
Colour	Black

Low Profile Cellular LTE



- Improves range
- Easy installation
- Lightweight solution

The Panorama LPB low profile antenna range has been designed to perform in any environment. At only 82mm (3.22") high and in a robust high impact radome, the antenna is almost impervious to daily wear, tear and impact.

The LPB offers excellent performance across a wide bandwidth. Mounted on a 400 x 400mm (15.75" x 15.75") ground plane, it covers LTE and global cellular bands in the ranges of 698-960 MHz and 1710-2700MHz, making it an extremely versatile product.

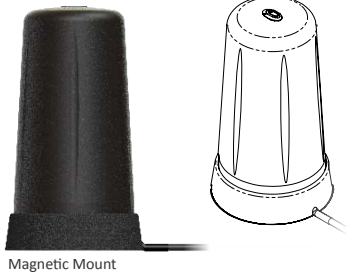

Variants

Panel Mount

Part No.	Termination	Cable Length
LPB-7-27-05SP	SMA Plug	0.5 (19.6")
LPB-7-27-5SP	SMA Plug	5 (16'5")
LPB-7-27-5F	FME Jack	5 (16'5")

Magnetic Mount

Part No.	Termination	Cable Length
LPBEM-7-27-2SP	SMA Plug	0.5 (19.6")
LPBEM-7-27-2F	SMA Plug	5 (16'5")

Standard Data

Part No.		
Frequency (MHz)	698-960 / 1710-2700	
Peak Gain: Isotropic	3dBi (700/800) 4dBi (900/1800) 5dBi (1900/2100/2400/2600)	
Pattern	Omni-directional	
Mechanical Data		
Dimensions (mm)	Height	82 (3.2')
	Width	48 (1.9')
Material	High-impact UV stable ABS	
Mounting Type	Automotive industry grade adhesive pad	
Ingress Protection	IP66	

On Glass Cellular LTE

700 MHz LTE, Quadband Cellular, 3G UMTS, AWS
LTE / WiMAX 2.6 GHz
Discreet adhesive pad fitment
Suitable for mounting to plastic or glass

EF-BC3G-26 is a highly efficient window mount 4G / 3G / 2G antenna for discreet or covert installations. The antenna is easily positioned on a vehicle windscreen using the supplied automotive industry grade adhesive pad. The antenna can be installed on a non-metallic panel if required and is constructed from weather resistant plastic, making it suitable for installation in semi-exposed scenarios.

The antenna covers the full range of LTE & cellular 4G frequencies globally.



Variants

Part No.	Termination
EF-BC3G-26-3SP	SMA Plug
EF-BC3G-26-3FAKRAD	FAKRA D Jack

Standard Data

Part No.		
Frequency (MHz)	698-960 / 1710-2170 / 2396-2700	
Operational Bands	LTE 700, GSM 850, CDMA 850, GSM 900, GSM 1800, PCS 1900, 3G UMTS, AWS, LTE / WiMAX	
Peak Gain: Isotropic	2dBi	
Max Input Power (W)	25	
Mechanical Data		
Dimensions (mm)	Height	131 (5.2")
	Width	21.7 (0.9")
Material	ASA	
Mounting Type	Automotive industry grade adhesive pad	
Cable Data		
Type	RG174	
Length (m)	3 (10')	
Diameter (mm)	5 (0.2')	

2x2 or 3x3 MiMo WiFi Antenna



- Rugged low profile design
- Ground plane independent
- Optional GPS version (2 x 2 MiMo only)

With either two or three omni-directional dual band WiFi elements in a single housing, the LPM /LGM series is an ideal solution for WiFi modems and routers that require MiMo connectivity.

Each element covers both the 2.4GHz and 5GHz bands. Supplied with short fly leads, the LPM/LGM series is easy to install.

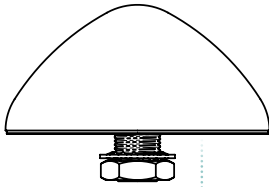

Ground Plane Independent

This antenna does not require a ground plane, and maintains a high level of performance even when mounted on a non-metallic surface.

Variants

	GPS	2 x 2 WLAN	3 x 3 WLAN
LPM2-24-58		●	
LPM3-24-58			●
LGM2-24-58	●	●	



Standard Data

Electrical Data		
Frequency (MHz)		2400 / 4900-6000 (2.4GHz WiFi / 4.9GHz WIMAX / 5.8 GHz WiFi)
		1562 (GPS)
Peak Gain: Isotropic		2dBi (individual elements)
Pattern		Omni-directional
Max Input Power (W)		25 watts
Mechanical Data		
Dimensions (mm)	Height	50 (1.97")
	Diameter	102 (4")
Material		ABS
Mounting type		Panel mount

Internal On Glass WiFi Antenna

- Compact dipole antenna
- Flexible moulded design
- Integral sealed coaxial cable

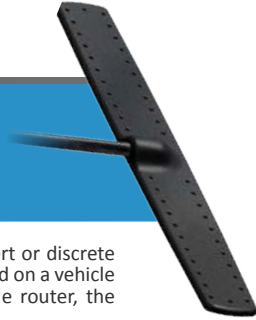

The EF-W24 range of antennas is a flexible dipole type, suitable for covert or discrete installations. The antenna is supplied with an adhesive pad and can be fixed on a vehicle window glass or plastic trim panel. Ideal for connection to an in-vehicle router, the antenna can provide a 2.4GHz wireless hot spot function.

Using two of these antennas, with the correct minimum spacing, can provide an effective MiMo antenna system. The antenna is supplied with a reverse polarity SMA plug as standard, to suit most router devices. A version with standard SMA plug is also available.

Part No.	EF-W24
Frequency (MHz)	2400-2485
Operational Bands	2.4 GHz WIMAX
Peak Gain	0dBd (Unity)
Impedance	50Ω
Max. Input Power (W)	10
Mechanical Data	
Material	TPE
Termination	SMA or SMA Rev. Pol.

WiFi 'Paddle' Terminal Antenna

- Dual Band 2.4 / 5.0GHz
- Suitable for routers and terminals
- Articulated connector



The PWB-24-58 antenna is a ground plane independent antenna covering 2.4 / 5.0GHz. Designed for distributing signal from WiFi terminals and routers, the PWB-24-58 offers an articulated connector for flexible positioning and a sleek profile for low visual impact.

Electrical Data	
Frequency (MHz)	2400-2485
Operational Bands	2.4 GHz WIMAX
Peak Gain	0dBd (Unity)
Impedance	50Ω
Max. Input Power (W)	10
Mechanical Data	
Material	TPE
Termination	SMA or SMA Rev. Pol.

Variants

Part No.	Termination
PWB-24-58-RSMAP	SMA Plug
PWB-24-58-RSMARV	SMA Plug (Rev. Pol.)

Compact Dual Band WiFi Antenna



- Compact, stylish shape
- Covers 2.4 & 5GHz for WiFi/WLAN
- Optional GPS version

The GPSF-24-58 is a dual function, compact 'fin' style antenna offering 2.4GHz / 5GHz WiFi coverage along with an active GPS element, all within one housing.

The FIN-24-58 features the same compact housing and dualband WiFi function but without GPS.

The antenna only requires a single hole for mounting and is installed on the roof of a vehicle. The combination of a low profile design and multi-functionality that the fin offers makes it an ideal choice for logistics and fleet vehicles.



GPS



Public Safety



Transport



GROUND PLANE INDEPENDENT

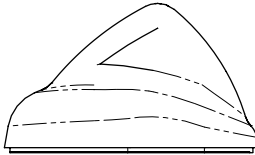

Variants

WiFi GPS

GPSF-24-58	●	●
FIN-24-58	●	

Ground Plane Independent

This antenna does not require a ground plane, and maintains a high level of performance even when mounted on a non-metallic surface.

Standard Data

Electrical Data	
Frequency Range (MHz)	2400 / 4900-6000 (WiFi) 1575 (GPS)
Gain: Isotropic	2dBi
Impedance	50Ω
Pattern	Omni-directional
Impedance	50Ω
Max Input Power (W)	50
Mechanical Data	
Operating Temp (°C)	-40° / +80°C (-40° / 176°F)
Colour	Black

Dual Band WiFi Panel Antenna

High gain directional antenna
Covers 2.4 & 5GHz for WiFi/WLAN
Ideal WiFi coverage extender

This mini panel antenna is a dual band WiFi antenna covering 2.4 & 5GHz. The antenna can be used internally or externally and has 60° beam width in both azimuth and elevation planes.

The antenna is supplied with a 90 degree adjustable angle bracket to give optimal mounting flexibility.

Ideal for use with a WiFi router, the W24-58-CP-9 is a cost effective solution for in- building or vehicle applications.

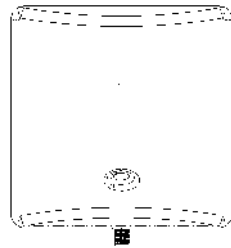

Adjustable Hinge Bracket

The W24-58-CP-9 comes supplied with a bracket that allows lateral adjustment to the installed angle of the antenna.

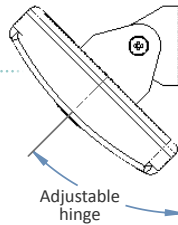

Standard Data

Electrical data		
Frequency Range (MHz)	2400-2485 / 4900 - 6000	
Operational Bands	2.4GHz / 5GHz WLAN	
Current	9dBi	
3dB Beamwidth	Azimuth 2.4GHz	60°
	Azimuth 5GHz	90°
Max Input Power (W)	50	
Mechanical Data		
Dimensions (mm)	Width	93 (3.6")
	Height	93 (3.6")
	Depth	25 (1")
Operating Temp (°C)	-30°/+80°C (-40°/ +176°F)	
Material	Geloy PC/ASA & die cast aluminium	

Dipole Antenna



- Dipole construction
- Covert bumper mounting
- Flexible wire elements for easy positioning

The covert vehicle dipole antenna is specifically designed for installations where the presence of an antenna must be undetectable.

This specialist antenna is available in versions for VHF or UHF bands and requires tuning during installation to achieve optimal VSWR match. The antenna feed incorporates a 'Bazooka' balun to improve the frequency stability.

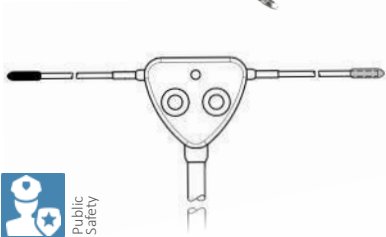

Variants

Part No.	Frequency (MHz)
VCD-VL-5F	68-88
VCD-VH-5F	130-175
VCD-S1-5F	380-400
VCD-S2-5F	410-430
VCD-S4-5F	450-470



Standard Data

Electrical Data	
Peak Gain	2dBi
Compared to ¼ wave	0dB
Ground plane	Not required
Impedance	50Ω
Max Input Power (W)	100

Bodyworn Dipole

Dipole antenna
Tuning optimised to individuals body
Flexible wire elements
Features fully molded T-piece

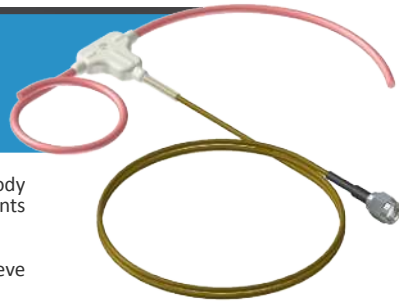

This antenna can be incorporated in clothing or body armour/stab vests and should be oriented with elements on a vertical plane.

Once in position, the antenna can be tuned to achieve the optimum VSWR/match.

Variants

Part No.	Freq. (MHz)	Part No.	Freq. (MHz)
BWDT-H3	132-143	BWDT-T2	420-450
BWDT-H4	141-151	BWDT-S4	450-470
BWDT-H5	149-159	BWDT-495	470-520
BWDT-H6	156-162	BWDT-815	806-870
BWDT-H7	162-174	BWDT-24	2400
BWDT-TET	380-430		

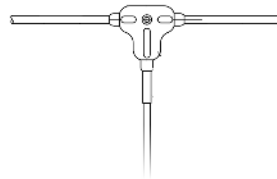

Standard Data

Electrical Data	
Peak Gain	2dBi
Impedance	50Ω
Max Input Power (W)	10
Mechanical Data	
Operating Temp (°C)	-40°/+80°C (-40°/176°F)
Material	Grey TPE
Colour	Grey
Antenna Elements	
Type	Multistrand copper wires
Colour	Pink
Termination Data	
Connector	BNC / SMA

Bumper Antenna

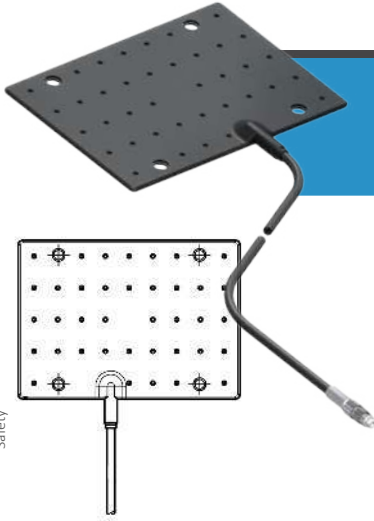

- Fully covert application
- Mounted behind plastic bumper
- Flexible construction
- Does not require any tuning

The Panorama Bumper Mount Antenna is designed for covert operations and other applications which require a vehicle antenna that is effectively invisible.

Mounted in the vehicle's bumper, installation requires no drilling and is invisible from the outside of the car.

For optimum performance two bumper antennas can be used, one at the front of the vehicle and one at the rear, to help create a more omni-directional pattern around the vehicle and enable better network coverage. The BMP2 kits come complete with a power divider and 2 bumper mount antennas.



Standard Data

Electrical Data	
Peak Gain: Isotropic	Vary on installation
Bandwidth @ 2:1 VSWR	10%
Pattern	Omni-directional
Max Input Power (W)	25 (5 for BMP2)
Mechanical Data	
Operating Temp (°C)	-40°/+80°C (-40°/+176°F)
Material	TPE
Dimensions (mm)	Length 140 (5.5")
	Width 100 (3.9")
	Diameter 4 (0.1") (including adhesive pad)
Fixing	Adhesive pad & 4 × fixing holes
Termination Data	
Connector	FME socket/BNC

Variants

Part No.	Frequency (MHz)
BMP1-S1	380-400
BMP1-S2	410-430
BMP1-U	430-472
BMP1-S4	450-470
BMP1-7-27	700-2700

Dual Version

Part No.	Frequency (MHz)
BMP2-S1-DPD	380-400
BMP2-S2-DPD	410-430
BMP2-S4-DPD	450-470

BMP2-DPD

Combine two BMPs with a splitter to maximise coverage.



Internal On Glass Antenna

Semi covert window mount antenna
Install with no vehicle damage
Flexible moulding to allow fitting to curved glass

The EF 'easy fit' antennas provide an effective low-visibility 'no-hole' solution.

With their secure but easy to fit adhesive pad mountings, the EF antenna provide a huge range of possibilities for the installer and is ideal for temporary installation in short-term use vehicles.

Variants

Part No.	Freq. (MHz)	Part No.	Freq. (MHz)
EF-S1	380-400	EF-W	470-512
EF-S2	410-430	EF-S5	806-870
EF-S3	380-420	EFBAD	698-960
EF-S4	450-470		

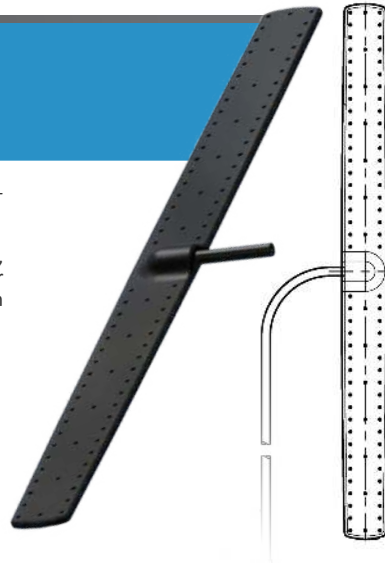

Standard Data

Electrical Data	
Peak Gain	2dBi
Impedance	50Ω
Max Input Power (W)	30
Mechanical Data	
Operating Temp (°C)	-40°/+80°C (-40°/176°F)
Material	TPE
Colour	Black
Ingress Protection	IP65
Termination Data	
Connector	Various available on request



Configure Your Cable

Turn to page 59-60 to select a cable set and connectors for this product. Panorama's wide range of adaptor cables means that it's simple to get the right termination for any antenna application.

Ceiling Mount UHF Antenna



- Easy installation
- In building UHF coverage
- Suitable for airports and stadiums

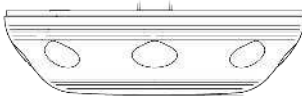

The Panorama UHF ceiling antenna can be used to provide network coverage in large buildings for the emergency services. Used in airports, large campus sites and shopping centres the antenna can help to reduce holes in coverage and improve signal strength.

Variants

Part No.	Frequency (MHz)
CM-S1-08NJ	380-400
CM-S2-08NJ	410-430
CM-S4-03NJ	450-470



Standard Data

Electrical Data		
Gain: Isotropic		0dBi
Pattern		Omni-directional
Impedance		50Ω
Max Input Power (W)		25
Mechanical Data		
Dimensions (mm)	Height	42
	Width	160
Operating Temp (°C)		-40°/+80°C (-40°/176°F)
Material		ABS
Colour		White (RAL9010)
Mounting Data		
Fixing		Ceiling tile mounting
Mounting hole size (mm)		18
Cable Data		
Length (m)		0.8
Termination		N Socket

Ultra-wideband Ceiling Mount

- Discreet ceiling mount design
- Future-proof UHF and cellular coverage
- Flame retardant radome
- Low PIM

Panorama's CMWB038-3-NJ allows businesses and facilities to support multi-service / multi-operator wireless coverage. A huge number of services are supported from 380MHz UHF to 6GHz - including TETRA UHF, GSM900, AWS 1700MHz, Quadband GSM, 3G UMTS, 2.4GHz WLAN, LTE & WiMAX etc. enabling simultaneous connectivity for employees, consumers and emergency services and providing in-building service providers and DAS installers with a convenient one size fits all solution.

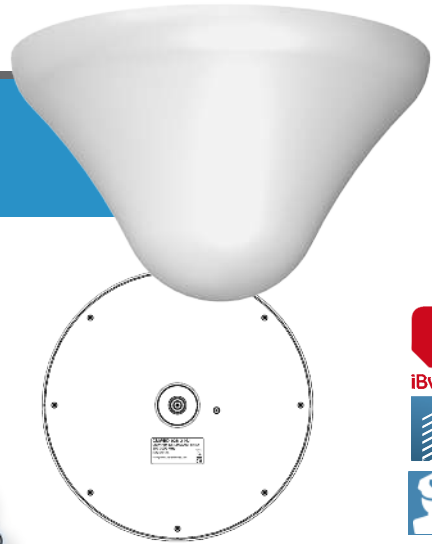

Featuring PIMGuard™

This product features Panorama Antennas' PIM Guard Technology and will meet or exceed a third order intermodulation level of <math><-140\text{ dBc}</math> (2 x 43 dBm)



Standard Data

Part No.		CMWB038-3-NJ
Frequency Range (MHz)	380-470, 698-960, 1710-6000	
Operational Bands	UHF/2G/3G/4G/WLAN/WiMAX	
Radiation pattern	Omni-directional	
Typical VSWR	< 2.5:1	
Peak Gain	2dBi (698-960) 5dBi (1710-2170) 7dBi (2200-6000)	
Typical Passive intermod. (2x20W, 3rd ord.) dBc+	< -140	
Mechanical Data		
Dimensions (mm)	Height	150 (5.9")
	Diameter	266 (10.47")
Material	Geloy PC/ASA (chlorine and bromine free)	
Flame Retardance	UL94-V0 (chlorine and bromine free)	
Mounting Data		
Fixing	N socket lock wheel	
Diameter (mm)	6 (0.24")/16 (0.6")	
Depth (mm)	41 (1.6")	
Termination	N Socket	

*Typical range PIM performance verified @ 1900MHz under controlled conditions by Anritsu PIM Master test equipment.



High-gain UHF Directional

- 8dBi peak gain
- Directional panel antenna
- Wall or mast mount

The WM8-TET is a directional panel antenna for UHF frequencies with a peak gain of 8dBi.

The heavy duty ASA radome is resistant to weathering and suitable for outdoor use in challenging environments. The enclosure is vented by a high performance GORE® gland which allows it to breathe while keeping moisture and contaminants out, further increasing service life.

Supplied with a multi-tilt wall and mast mount bracket the WM8-TET-NJ is perfect for inbuilding or light duty infrastructure applications.



Variants

Circularly Polarised

Part No.	Frequency (MHz)	Part No.	Frequency (MHz)	Polarisation
WM8-TET	380-450	WM8RCP-TET-NJ	380-430	RHCP
WM8-U2	450-520	WM8LCP-TET-NJ	380-430	LHCP

Standard Data

Electrical Data		
Peak Gain: Isotropic		8dBi
Compared to a dipole		6dB
Pattern		Directional
Impedance		50Ω
Max Input Power (W)		100
Mechanical Data		
Dimensions (mm)	Height	416 (16.37")
	Width	416 (16.37")
	Depth	60 (2.36")
Materials		ASA & aluminium
Mounting Data		
Mounting type		Wall mount or mast mount
Termination Data		
Termination		N socket

VHF & UHF Combined Ceiling Mount

- Covers VHF and UHF frequencies
- Ceiling mount design
- Low smoke halogen free flame retardant radome



Panorama's ceiling mounted solution is a dual band VHF/UHF ceiling mounted antenna designed for short range inbuilding, DAS and network infill applications.

The antenna combines omni-directional VHF and UHF coverage in a single feed, minimising cable runs and allowing UHF radio systems to be integrated with existing VHF systems. The ceiling mount enclosure is weather-proof and constructed from flame retardant, low smoke, halogen free PC/ASA.



Variants

Part No.	Frequency (MHz)
CM-H7-TET-NJ	162-174 / 380-430
CM-H7-S4-NJ	162-174 / 450-470

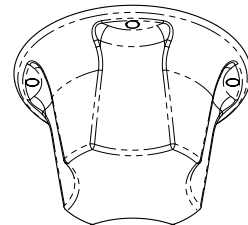
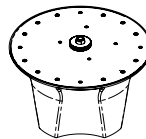

Standard Data

Electrical Data		
Radiation pattern	Omni-directional	
Peak Gain	-2dBi	
Max Input Power (W)	50 Watts	
Impedance	50Ω	
Mechanical Data		
Dimensions (mm)	Height	155mm (6.1")
	Diameter	266mm (10.5")
Operating Temp (°C)	-30° / +70°C (-22° /158°F)	
Material	Geloy PC/ASA (meets UL746C f1)	
Flame Retardance	UL94-V0 (chlorine and bromine free)	
Mounting Data		
Termination	N Socket	

Offset Dipole

Improves range
Easy installation
Light weight solution

The ODP wall mount antenna range is a simple and cost efficient way of providing a fixed antenna for terminals.

With 4 screw holes for mounting, the ODP is waterproof and can be fitted internally or externally.

Variants

Part No.	Frequency (MHz)	Gain
ODP-H5	149-159	2dBi
ODP-H6	156-162	2dBi
ODP-H7	162-174	2dBi
ODP-TET	380-430	2dBi
ODP-433	410-450	2dBi
ODP-S4	450-470	2dBi
ODP-S1G6-4B	380-400	6dBi
ODP-S2G6-4B	410-430	6dBi
ODP-S4G6-4B	450-470	6dBi



iBwave



- Black
- Grey

Standard Data

Electrical Data	
Polarisation	Vertical
Pattern	Omni-directional
Impedance	50Ω
Max Input Power (W)	20
Mechanical	
Operating Temp (°C)	-40°/+80°C (-40°/176°F)
Material	Engineering plastic
Colours	Black / Grey
Termination Data	
Cable/Connector	Various available on request

*Some variants listed

Bracket Mount

Used with fixed radio terminals
Improves range
Wall mount or mast mount options

The bracket mount antenna range is an easy to install solution, ideal for a fixed radio terminal in an office.

Emergency services often need a dispatcher radio and the BM range provides a simple and reliable solution for this application.

Variants

Part No.	Frequency (MHz)
BM390	380-400
BM420	410-430
BM451	430-472
BM460	450-470
BM-55	806-872
BM900	890-960

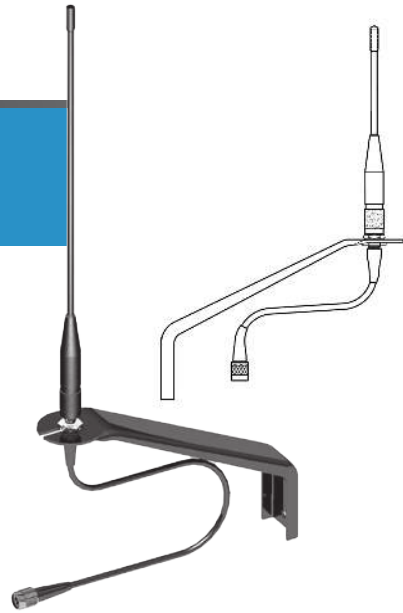

Standard Data

Electrical Data		
Gain: Isotropic	4dBi	
Pattern	Omni-directional	
Impedance	50Ω	
Max Input Power (W)	5	
Mechanical Data		
Dimensions (mm)	Total Length	555 (21.8")
	Length of whip	420 (16.5")
Operating Temp (°C)	-40°/+80°C (-40°/176°F)	
Mast diameter range (mm)	50.8 / 32.0	
Cable Data		
Type	CS23	
Length (m)	4.5 (14'9")	
Diameter (mm)	5 (0.2')	
Cable/Connector	Various available on request	

*Some variants listed

Modular Stud Mount Antenna Bases

The modular whip range are interchangeable and any whip will fit on any of the modular bases. This allows a high level of flexibility and a wide range of options to suit every application.

Permanent



Panel mount for a simple hole installation. The design ensures that installations are secure and watertight.

Temporary



Damage free and fast installations for drive testing or rental vehicles. These bases provide an effective solution where drilling holes is not possible.

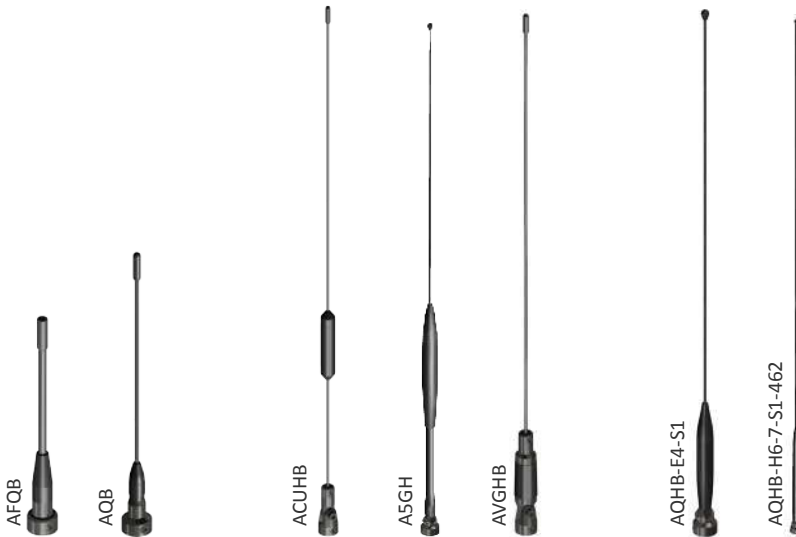

1/4 Wave

High Gain

Multi-band

M8 & M8A

Panel mount
Rugged design
Modular stud fitting
Interchangeable whips

The M8 is the “industry standard” panel mount base. It incorporates stainless steel earthing teeth and a fully moulded construction with high quality coaxial cable for low loss and long term reliability.

The base is easy to fit and can be installed from above or below the panel. With the modular stud fitting, almost any antenna in the Panorama range can be fitted to the base.

Part No.	M8	M8A
Dimensions (mm)	Base Height	15 (0.6")
	Base Diameter	28 (1.1")
Operating Temp (°C)	-40°/+80°C (-40°/+175°F)	-40°/+80°C (-40°/+176°F)
Material	Nylon, stainless steel & nickel plated brass	Nylon, stainless steel & nickel plated brass
Cable Data		
Type	CS23 (RG58 C/U)	CS23 (RG58 C/U)
Diameter (mm)	5 (0.2")	5 (0.2")
Length (m)	4.8 (16')	4.8 (16')
Termination	Bare end	Bare end



MMR & MBM

Temporary mount
Rugged design
Modular stud fitting
Interchangeable whips

The MMR is large secure magnetic base for professional use that supports a full range of antenna whips. It features a fully moulded construction with high quality coaxial cable.

The MBM is a boot clip base designed for secure fixing.



Part No.	MMR-5	MBM
Dimensions (mm)	Base Height	40.2 (1.6")
	Base Diameter	102 (4.0")
	Base Length	-
Material	Nylon & nickel plated brass	Nylon & nickel plated brass
Cable Data		
Type	CS23 (RG58 C/U)	CS23 (RG58 C/U)
Diameter (mm)	5 (0.2")	5 (0.2")
Length (m)	5 (16')	5 (16')
Termination	Bare End	Bare End

Panel Mount Base

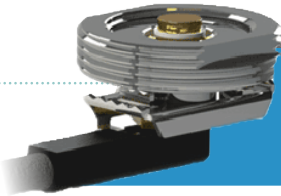

Panel mount
Suitable for various whips
Stainless steel earthing teeth

SAB-181



The NMO fitting can be converted to Panorama modular stud with the SAB-181 accessory. This allows use with the full modular antenna range.

The Panorama 'NMO' 3/4 inch panel mount antenna base combines compatibility with NMO style antennas with rugged engineering and high quality construction.

This quality panel mount is made from nickel plated brass to resist corrosion, and the earthing teeth are stainless steel to provide excellent earthing with every installation.



Part No.	MNMOM-5	MNMOM-5F
Dimensions (mm)	Diameter	28 (1.1")
	Height mounted	19 (0.75")
Operating Temp (°C)	-40°/+80°C (-40°/+175°F)	
Material	Nylon, stainless steel & nickel plated brass	
Cable Data		
Type	CS23	CS23
Diameter (mm)	5 (0.2")	5 (0.2")
Length (m)	5.2 (17')	5.2 (17')
Termination	Bare end	FME (f)

Panel Mount Base With GPS

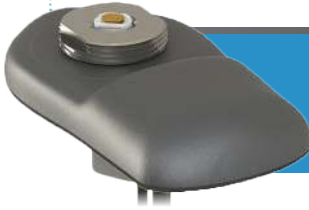

Panel mount
Rugged design
NMO fitting
Interchangeable whips

The GPSNMO is a GPS combination antenna that features a low-profile NMO mount and a high-performance GPS element with 26dB gain LNA.

This base fits on surfaces up to 6.5mm thick with a single hole.



Part No.	GPSNMO
Frequency Range	130-2700 (dependent on whip)
Base Diameter	102 (4.0")
GPS Data	
Frequency	1575
Gain: LNA	26dB
Termination Data	
Mounting Hole Size	19mm (3/4")
GPS Cable	SMA Plug
Comms Cable	Bare end

Rigid 1/4 Wave Whip

1/4 wave whip
Removable for car wash
Hinged & non-hinged versions

The AQB & AQHB are Panorama's standard single frequency 1/4 wave rigid whips. These antennas feature a 17-7 PH stainless steel rod with a plated brass terminal protected by black nylon moulding.

The Panorama mounting system provides a high degree of interchangeability between whips and bases, making them suitable for all applications whether temporary or permanent. For use with all Panorama modular bases and available for VHF & UHF frequency bands.

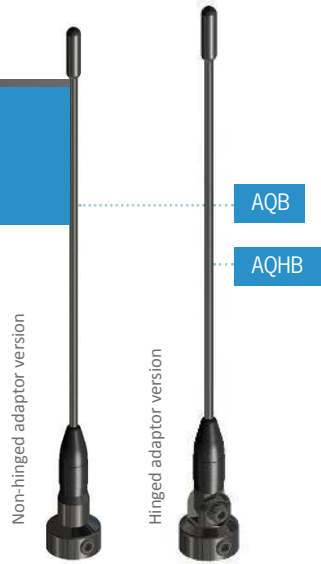

Variants

Hinged Version

Part No.	Freq. (MHz)
AQHB-H4A	138-155
AQHB-H6A	155-174
AQHB-TET	380-430
AQHB-U	430-472
AQHB-W	470-512
AQHB-S5	806-870

Non-hinged Version

Part No.	Freq. (MHz)
AQB-H4A	138-155
AQB-H6A	155-174
AQB-TET	380-430
AQB-U	430-472
AQB-W	470-512
AQB-S5	806-870

Standard Data

Electrical Data	
Peak Gain: Isotropic	2dBi
Compared to 1/4 wave	0dB
Polarisation	Vertical
Pattern	Omni-directional
Impedance	50Ω
Max Input Power (W)	100
Mechanical Data	
Operating Temp (°C)	-40°/+80°C (-40°/+175°F)
Material	Stainless steel & nylon
Colour	Black



Configure Your Base

Turn to page 38 to select a compatible base for this product. Panorama's wide versatile range of bases mean that it's simple to get the right solution for any antenna application.

ACUB

A5GH

ACUHB



Public Safety



Transport



Utility

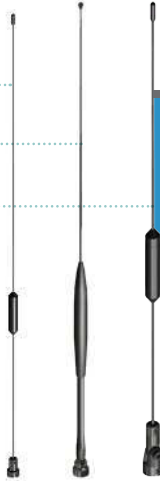

Colinear Gain Whips

High gain
Removable for car wash
Hinged & non-hinged versions

The A5G series is a broadband collinear antenna. The phasing coil is over-moulded to provide a rugged antenna for demanding applications.

The ACU series is a 7dBi gain antenna for use where network coverage is poor.

Both antennas are available in fixed or hinged versions.

Standard Data

Electrical Data	A5GH/A5GM	ACUB/ACUHB
Peak Gain: Isotropic	5dBi	7dBi
Compared to ¼ wave	3dB	5dB
VSWR	<2:1	
Polarisation	Vertical	
Pattern	Omni-directional	
Impedance	50Ω	
Max Input Power (W)	50	
Mechanical Data		
Operating Temp (°C)	-40°/+80°C (-40°/176°F)	
Material (coil)	Polyamide	
Material (whip)	17-7 Stainless steel	
Colour	Black	

Variants

Non-hinged

Part No.	Frequency (MHz)
A5GM-TET	380-430
A5GM-S4	450-470
ACUB-S1	380-400
ACUB-S2	410-430
ACUB-U	430-472
ACUB-460	450-470
ACUB-W	470-512

Hinged

Part No.	Frequency (MHz)
A5GH-TET	380-430
A5GH-S4	450-470
ACUHB-S1	380-400
ACUHB-S2	410-430
ACUHB-U	430-472
ACUHB-460	450-470
ACUHB-W	470-512



Configure Your Base

Turn to page 38 to select a compatible base for this product. Panorama's wide versatile range of bases mean that it's simple to get the right solution for any antenna application.

Medium Gain Whips

Gain whips

Rugged construction

Hinged base and removable whip

The AVHGB/AUGHB range is a durable solution for vehicle installations requiring a medium gain antenna. The antennas feature a fully encapsulated impedance matching coil and a 17-7PH stainless steel whip.

The AVHGB & AUGHB ranges are compatible with the full range of Panorama Antennas modular bases and incorporates a hinge to enable vertical orientation.

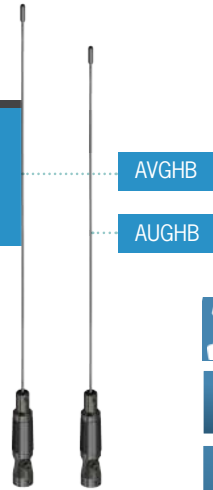

Variants

Part No.	Frequency (MHz)	Peak Gain
AUGHB-S1	380-400	3.5dBi
AUGHB-S2	410-430	3.5dBi
AUGHB-TET	380-430	3.5dBi
AUGHB-U	430-472	3.5dBi
AUGHB-460	450-470	3.5dBi

Part No.	Frequency (MHz)	Peak Gain
AVHGB-H4	141-151	5dBi
AVHGB-H5	149-159	5dBi
AVHGB-H6	156-162	5dBi
AVHGB-H7	162-174	5dBi

Standard Data

Electrical Data	
VSWR	<2:1
Polarisation	Vertical
Pattern	Omni-directional
Impedance	50Ω
Max Input Power (W)	50
Mechanical Data	
Operating Temp (°C)	-40°/+80°C (-40°/176°F)
Material (coil)	Polyamide
Material (whip)	17-7 Stainless steel
Colour	Black

VHF Wideband Antenna

Wideband VHF antenna
Integrated shock mount

The AVWB is a rugged wide band VHF antenna, suitable for users who operate over the full range of VHF frequencies.

The AVWB is compatible with all of the modular bases in the Panorama range.

Supplied with an integrated shock mount, the antenna is protected from impact and damage in low clearance situations.

The AVWB is compatible with all of the modular bases in the Panorama range.



Standard Data

Electrical Data		AVWB-SM-39-68
Frequency Range	VHF	138-169
Peak Gain	VHF	2dBi
VSWR		≤ 2.2:1
Maximum Input Power (W)		100
Mechanical Data		
Operating Temp (°C)		-40° / +80°C (-40° / +176°F)



Configure Your Base

Turn to page 38 to select a compatible base for this product. Panorama's wide versatile range of bases mean that it's simple to get the right solution for any antenna application.

3dB Gain Flexible Whips

- OEM bee-sting style
- High peak gain
- Flexible overmoulded construction

The AFGB offers omni-directional performance with 5dBi peak gain. The antenna whip is styled like an OEM 'bee-sting' type antenna and is both discrete and durable featuring an overmoulded coil and stainless steel rod.

The antenna base is flexible for added damage resistance and can be mounted on a range of Panorama GPS combination bases such as the GPSB and GPSK - please see page 8 for more information on the GPSB and page 9 for the GPSK.



Variants

Part No.	Frequency (MHz)	Part No.	Frequency (MHz)
AFGB-395	380-410	AFGB-832	760-870
AFGB-S2	410-430	AFGB-B1	745-806
AFGB-S4	450-470	AFGB-S5	806-870

Standard Data

Electrical Data	
Peak Gain: Isotropic	5dBi*
Typical VSWR	< 2:1
Polarisation	Vertical
Pattern	Omni-directional
Impedance	50Ω
Max Input Power (W)	60
Mechanical Data	
Operating Temp (°C)	-40° / +80°C (-40° / 176°F)
Material	Stainless Steel & TPE
Termination	M6 x 0.75

* Peak gain of AFGB-832 = 4dBi



VHF 1/4 Wave Flexible Whip

- OEM bee-sting style
- Wideband 1/4 wave
- Flexible overmoulded base

The AFBQ is a rugged VHF 1/4 wave whip for use on GPSK & GPSB base types. This antenna whip is styled to resemble an OEM 'bee sting' type design and is both discrete and durable, featuring an overmoulded shock spring and stainless steel rod.

Variants

Part No.	Frequency (MHz)
AFBQ-H4A	138-155
AFBQ-H6A	155-174
AFBQ-H5	149-159
AFBQ-H7	162-174

Standard Data

Electrical Data	
Peak Gain: Isotropic	2dBi
Typical VSWR	< 2:1
Polarisation	Vertical
Pattern	Omni-directional
Impedance	50Ω
Max Input Power (W)	60
Mechanical Data	
Operating Temp (°C)	-40° / +80°C (-40° / 176°F)
Material	Stainless Steel & TPE
Fixing	M6 x 0.75

¼ Wave Flexible Whips

1/4 wave whip

Removable for car wash

Rugged, flexible design

Suitable for GPSK, GPSB and GPSKM bases

This antenna features a flexible construction within a black nylon tube. This provides damage resistance without compromising RF performance. The Panorama mounting system provides a high degree of interchangeability between whips and bases, making them suitable for all applications whether temporary or permanent.

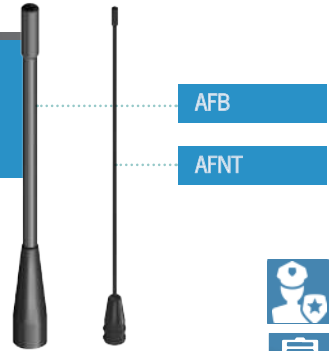

Variants

Part No.	Frequency (MHz)
AFB-S1	380-400
AFB-S2	410-430
AFB-TET	380-430
AFB-U	430-472
AFB-UT	406-472
AFB-S4	450-470
AFB-W	470-520
AFM-835	806-870

Part No.	Frequency (MHz)
AFNT-H4A	138-155
AFNT-H6A	155-174
AFNT-TET	380-430
AFNT-U430	450-470
AFNT-U2	450-512

Standard Data

Electrical Data	
Gain: Isotropic	2dBi
Compared to 1/4 wave	0dB
Polarisation	Vertical
Pattern	Omni-directional
Impedance	50Ω
Max Input Power (W)	100
Mechanical Data	
Operating Temp (°C)	-40° / +80°C (-40° / 176°F)
Fixing	M6 x 0.75 (GPSB, GPSD, GPSK & MAR bases)



Configure Your Base

Turn to page 38 to select a compatible base for this product. Panorama's wide versatile range of bases mean that it's simple to get the right solution for any antenna application.

Tri Band Whip

Tri band performance
Flexible rod with wound element
Fits Panorama GPS combination bases

This whip is stylish, discrete and durable, featuring a flexible overmoulded base section and a black jacketed flexible wound rod element.

This whip is designed to be mounted on the GPSB, GPSD and GPSK range of bases - please see the respective product pages in this catalogue for more information on these bases.



Variants

Part No.	Frequency (MHz)
ASFC-155-U2-B1	150-160 / 450-512 / 745-806
ASFC-155-U2-S5	150-160 / 450-512 / 806-876
ASF-155-S4-821	150-160 / 450-470 / 764-896
AS-H5-6-7-S1-440	148-174 / 380-400 / 430-450
AS-E4-TET	73-80 / 380-430

Standard Data

Electrical Data	
Peak Gain: Isotropic	2dBi
Typical VSWR	< 2:1 @ VHF / < 2.5:1 @ UHF / < 2:1 @ 800MHz
Polarisation	Vertical
Pattern	Omni-directional
Impedance	50Ω
Max Input Power (W)	60
Mechanical Data	
Operating Temp (°C)	-40° / +80°C (-40° / 176°F)
Material	Flexible TPU, FRP, EPDM
Colour	Black

VHF / UHF Diplexer

Allows dual band antenna to be used with 2 radios
4m OR 2m VHF & UHF Bands



The Panorama VHF/UHF diplexer is housed in a compact, robust die cast case for reliability and easy mounting.

This Diplexer allows the Panorama dual band antenna to be used with 2 single band radios.

The Diplexer uses a stripline design to provide low insertion loss with high port to port isolation and high power handling capability.



Public
Safety

Standard Data

Electrical Data		DPX-210-270
Frequency Range (MHz)	VHF	50 - 210
	UHF	270 - 1000
Insertion Loss	VHF	< 1dB
	UHF	< 1dB
Min. port-to-port isolation		> 40dB
Maximum Input Power		100
Mechanical Data		
Dimensions (mm)	Length	100 (3.9")
	Width	90 (3.5")
	Height	20 (0.8")
Operating Temp (°C)		-30°/+70°C (-22°/+158°F)
Material		Aluminium
Colour		Black
Termination		FME on all ports(male)
Mounting Data		
Fixing		4 × Mounting holes



VHF / UHF / 7-800MHz Triplexer

- Use one antenna for 3 radios or vice versa
- VHF, UHF, 7/800MHz
- Low insertion loss, high port-to-port isolation

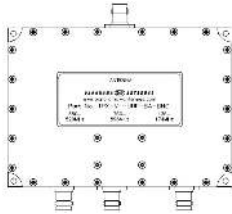

The Panorama triplexer, TPX-VH-UHF-BA-TNC can either combine the signals from three antennas to a single multiband radio or split the signal from a tri-band antenna to three separate radios. Each port provides a low insertion loss passband for the respective frequency range. The unit is available with TNC female connector type on each port

This compact unit requires no power and can easily be installed in the roof lining of any vehicle or mounted next to the radio.

Standard Data

Electrical Data		TPX-VH-UHF-BA-TNC
Frequency Range (MHz)	VHF	136-174
	UHF	380-520
	7/800	760-896
Insertion Loss	VHF	< 1dB
	UHF	< 1dB
	7/800	< 1dB
Isolation between ports		> 55dB
Maximum Input Power		150 Watts
Mechanical Data		
Dimensions (mm)	Length	140 (5.5")
	Width	100 (3.94")
	Thickness	25 (0.98")
Operating Temp (°C)		-20° / +80°C (-4° / +175°F)
Material		Aluminium
Termination		TNC sockets on all ports
Mounting Data		
Fixing		4 × Mounting holes

VHF / UHF With 7-800MHz Diplexer

Use one antenna for 2 radios
Splits VHF & UHF from 7/800MHz & cellular
Easy to install

The DPX-500-700 offers the opportunity to utilise a single multiband antenna with two radios. This conserves valuable vehicle real estate and saves on antenna installation costs.

The diplexer has low loss characteristics and is perfect for splitting a single antenna to a VHF or UHF radio and a 7/800MHz radio.

The diplexer is compact enough to locate in a vehicle headliner and is fitted with FME (m) connectors.



Standard Data

Electrical Data		DPX-500-700
Frequency Range (MHz)	VHF / UHF	50 - 500
	700-2500MHz	700- 2500
Max. in-band insertion loss	VHF / UHF	< 0.75dB
	700-2500MHz	< 0.75dB
Min. alternate Band Rejection	VHF/UHF	>-40dB
	700-2500MHz	>-30dB
Min. port-to-port isolation		> 25dB
Maximum Input Power		50 Watts
Mechanical Data		
Dimensions (mm)	Length	91 (3.58")
	Width	61 (2.4")
	Height	14 (0.55")
	(°C)	-30°/+70°C (-22°/+158°F)
Material		Aluminium
Termination		FME plugs on all ports
Mounting Data		
Fixing		4 × Mounting holes
Hole diameter (mm)		4 (0.16")

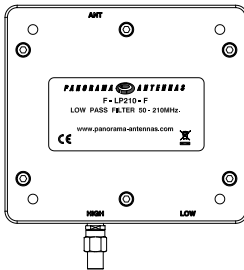

F-HP270-F - High Pass Filter F-LP210-F - Low Pass Filter

- Low insertion loss
- High out of band rejection

The F-HP270-F offers an ideal solution for protecting UHF transmitters from out of band interference. The F-HP270-F can be used with the F-LP210-F to protect co-located VHF / UHF systems from interfering with each other if this is a concern.

The filter has very low insertion loss characteristics combined with exceptional out of band rejection.

The filter is compact enough to locate in a vehicle headliner and is fitted with FME (m) connectors on all ports.

Standard Data

		F-LP210-F
Frequency pass range (MHz)		0-210
Max. in-band insertion loss		< 0.5dB
Min. out of band attenuation (dB)	270-1000MHz	> -30dB
	380-430MHz	> -60dB
Typical VSWR		<1.5:1
Maximum Input Power		50 Watts

		F-HP270-F
Frequency pass range (MHz)		270-1000
Max. in-band insertion loss	270-1000MHz	< 0.8dB
	380- 430MHz	< 0.2dB
Min. out of band attenuation (dB)	0-210MHz	> -45dB
	136-174MHz	> -60dB
Typical VSWR		<1.5:1
Maximum Input Power		50 Watts

UHF Antenna Combiner

- Combines two UHF radios on the same antenna
- Combines two antennas on the same radio



When you can only fit one antenna on a vehicle, then this combiner is the solution providing > 26dB isolation over 380-430MHz with an antenna match at 1.2:1 and low insertion loss.

Technical Note:

The isolation provided by this device is dependent on the antenna VSWR. An antenna match of 1.5:1 VSWR will result in a reduction of isolation to 20dB. Higher VSWR on the antenna port will result in a further reduction in isolation between the TX ports. During operation extreme care should be taken to ensure that the VSWR of the antenna connected to the combiner does not exceed 1.5:1.



Standard Data

Part No		DBLC-TET-N
Frequency Range (MHz)		380-430
Split Loss		3dB
Insertion Loss		< 0.5dB
Isolation TX1 - TX2	≥ 26dB	VSWR of 1.1:1 at antenna port
	≥ 26dB	VSWR of 1.2:1 at antenna port
	≥ 20dB	VSWR of 1.5:1 at antenna port
VSWR at Tx1 / Tx2	< 1.5:1	VSWR of 1.5:1 at antenna port
Max Input Power (W)		20 per port
Mechanical Data		
Dimensions (mm)	Length	72 (2.83")
	Width	72(2.83")
	Height	23 (0.90")
Operating Temp (°C)		-40° / +80°C (-40° / 176°F)
Material		Aluminium
Termination		N sockets on all ports

GPS Splitter



- Reduce installation costs
- Run two GPS receivers from a single antenna
- DC block on one port



The Panorama DPD-GPS allows you to run two GPS receivers from a single antenna. The DPD-GPS splits the received signal from the antenna to two receivers while only allowing one of the receivers to feed voltage to the antenna ensuring that the antenna is able to function correctly.

The DPD-GPS is perfect for ensuring that both GPS receivers can use an optimally located antenna, thereby reducing clutter and installation costs.

Standard Data

Part No.		DPD-GPS
Frequency Range (MHz)		1575
Insertion Loss		< 0.5dB
Isolation between GPS ports		> 15dB
Impedance		50Ω
Max Input Power		1W
DC Feed voltage		Fed via Rx1 Port
Mechanical Data		
Dimensions (mm)	Height	14 (0.5")
	Length	47.8 (1.8")
	Width	56 (2.2")
Operating Temp (°C)		-30° / +80°C (-22° / 176°F)
Material		Aluminium
Connectors		FME plugs on all ports
DC Feed connector		FME plug

UHF Splitter

Optimise antenna performance
Connect two antennas to one radio

The HPDPD-550 series is a range of power dividers designed to split the power from a radio to distribute it to two separate antennas. Designed to support Panorama Antennas' covert VCD (VHF) and BMP (UHF) bumper / fender mount antennas the HPDPD-550 range comes in three variants for up to 15W, 60W and 150W Input Power respectively,

Covering a frequency range from 50-550MHz the HPDPD efficiently distributes power to two antennas with very low losses allowing users to distribute covert antennas at opposite ends of a vehicle to ensure maximal coverage.

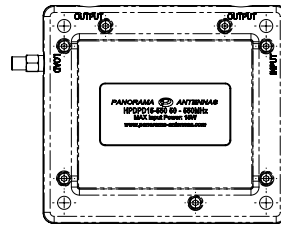

Variants

Part No.	Max. Input Power
HPDPD15-550	15
HPDPD60-550	60
HPDPD150-550	150

Standard Data

Part No.		
Frequency Range (MHz)		50-550
Insertion Loss		< 0.5dB
Isolation between output ports		> 25dB
Impedance		50Ω
Mechanical Data		
Dimensions (mm)	Height	16 (0.6")
	Length	108 (4.2")
	Width	121 (4.7")
Operating Temp (°C)		-30° / +80°C (-22° / 176°F)
Material		Aluminium
Connectors		FME plugs on all ports



MTP850 Adapter

Remote antenna adaptor for Motorola MTP850 radio
Spring loaded contact pin
Sturdy quick release lock

For Motorola MTP850

The ADPT-85-055J is for use with Motorola MTP850 series portable terminals.

A 'one of a kind product' the ADPT-85-055J is specifically designed for use with the Motorola MTP850 TETRA radio. With spring loaded contact pin and durable quick fit/release feature, the ADPT is both simple to connect and reliable to use. Designed for use with any antennas from Panoramas' temporary, vehicle and body worn ranges the ADPT unlocks the full potential of the MTP850 radio for covert, surveillance and other tactical applications.

Note: The standard belt clip cannot be used in conjunction with this adaptor.

Standard Data

Mechanical Data		MTP850
Dimensions (mm)	Height	47 (1.9")
	Width	30 (1.2")
	Depth	19 (0.7")
Operating Temp (°C)		-40° / +80°C (-40° / 176°F)
Material		PC/ABS
Colour		Black
Cable Data		
Type		RG316
Diameter (mm)		3 (0.12")
Length (m)		0.5 (1'7")
Termination		SMA Jack

Compatible Antennas

- BWDT** - Bodyworn Dipole (covert surveillance)
- MD-TET** - Magnetic Base TETRA Antenna (temporary vehicle)
- EF Series** - Covert TETRA Antenna (vehicle covert)
- CD Series** - Clip Dipole (temporary fixed)

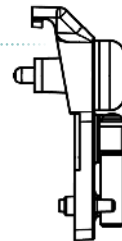

Ultra-flexible UHF Antenna

Radio specific ¼ wave whip
 Ultra-flexible multi strand wire whip
 Fully moulded connector
 Ideal for covert/bodyworn applications

This antenna features an ultra-flexible ¼ wave whip. Tuned to match the radio characteristics, it will provide consistent performance across the full operating frequency range.

The durable, ultra-flexiwire design with moulded connector makes it ideal for covert and body worn radio use.

















Variants

Part No.	Compatibility
SFQ-SRP2-TET	Sepura SRP/SRH
SFQ-MT8-TET	Motorola MTP850

Standard Data

Electrical Data		SFQ-MT8-TET
Frequency Range (MHz)		380-430
Gain: Isotropic		2dBi
Compared to ¼ wave		0dB
Bandwidth @ 2:1 VSWR		20%
Polarisation		Vertical
Pattern		Omni-directional
Impedance		50Ω
Max Input Power (W)		50
Mechanical Data		
Dimensions (mm)	Total Height	180 (7.1")
	Height of Whip	11 (0.43")
Operating Temp (°C)		-40° / +80°C (-40° / 176°F)
Material		Stainless steel & PVC
Colour		Black
Connector		MTP850

Connector	Antenna
	BNC MXK, PXX, MVQ, MFX, MQ, MFXU
	ICF4 XPK, MFX, MQ, MFXU
	ICF5 PXX, MFX, MFXU, MQ
	ICF9 MFX, MFXU, MQ
	MX MXK, PXX, MVQ, MFX, MQ, MFXU
	MG MXK, PXX, MVQ, MFX, MQ MFXU
	MV MXK, PXX, MVQ, MFX, MQ MFXU
	PRP73 MXK, MFX, MFXU
	SL100 PXX, MFX, MQ MFXU
	SMAFR PXX, MFX, MQ MFXU
	SMAMO MXK, MFX, MQ MFXU
	TNC MXK, PXX, MVQ, MFX, PUG, MQ MFXU
	TNK MXK, PXX, MVQ, MFX, MQ MFXU
	TNM MXK, PXX, MVQ, MFX, MQ MFXU
	VX-410 PXX, MFX, MQ MFXU

Portable Antennas

Panorama supplies portable antennas to many of the world's leading radio OEM manufacturers. This is due to our advanced design process, material selection and strict production control, to ensure that we supply accurately tuned and reliable products.

In addition to OEM supply, Panorama offers a comprehensive range of antennas for a wide range of portable radios, with differing connector types. As with our OEM products, the MFX, MXK, PXX helical and MQ UHF ¼ wave types are totally overmoulded in TPE or TPU thermoplastic.

Our other portable antennas feature a rugged Nylon moulding to secure the outer sleeve to the terminal. These features contribute to both the performance and the service life of the antenna.



Part No.	MXK	PXX	MFX	MFXU	MVQ	MQ	PUG
Description	moulded compressed helical	moulded compressed helical	moulded VHF helical	moulded UHF helical	moulded UHF quarterwave	moulded UHF quarterwave	UHF halfwave
Freq. (MHz)	67-88	141-225	141-366	330-512	141-336	330-512, 698-960	350-512
Length (inch)	7.68 @ 68MHz	3.25 @ 146MHz	6.69 @ 451MHz	2.84 @ 451MHz	19.69 @ 146MHz	6.14 @ 451MHz	13.39 @ 451MHz
Max Diameter (mm)	14	10	10	10	14	11	16

Cables



RG174 Type | GPS

Outer Diameter (mm)	2.8 (0.1")
Attenuation (per 10m)	1.25 dB @ 1.575GHz



CS23 Type | VHF - UHF

Outer Diameter (mm)	5 (0.2")
Attenuation (per 10m)	3.6 dB @ 450MHz 5.5 dB @ 1GHz 8.8 dB @ 2GHz



CS29 Type | 4G/3G/2G LTE

Outer Diameter (mm)	5 (0.2")
Attenuation (per 10m)	2.5 dB @ 450MHz 3.8 dB @ 1GHz 5.9 dB @ 2GHz



CS32 Type | WiFi

Outer Diameter (mm)	5 (0.2")
Attenuation (per 10m)	2.6 dB @ 450MHz 3.7 dB @ 1GHz 5.6 dB @ 2GHz 10 dB @ 6GHz

5m+ Extensions

CS240 Type

Outer Diameter (mm)	6 (0.2")
Attenuation (per 10m)	2.5 dB @ 1GHz 3.8 dB @ 2GHz 7 dB @ 6GHz

Ultra Low Loss 10mm

CS400 Type

Outer Diameter (mm)	10.29 (0.4")
Attenuation (per 10m)	1.4 dB @ 1GHz 2 dB @ 2GHz 3.6 dB @ 6GHz

Coaxial Adaptors



Part No.	CA-BP-FP	CA-FP-FP	CA-MP-FP
Termination 1	BNC Plug (male)	FME Plug (male)	Mini-UHF Plug (male)
Termination 2	FME Plug (male)	FME Plug (male)	FME Plug (male)



Part No.	CA-NP-FP	CA-PLP-FP	CA-SP-FP
Termination 1	N Plug (male)	PL259 Plug (male)	SMA Plug (male)
Termination 2	FME Plug (male)	FME Plug (male)	FME Plug (male)



Part No.	CA-TP-FP	CA-FJ-FJ
Termination 1	TNC Plug (male)	FME Jack (female)
Termination 2	FME Plug (male)	FME Jack (female)

Frequency Band Plan

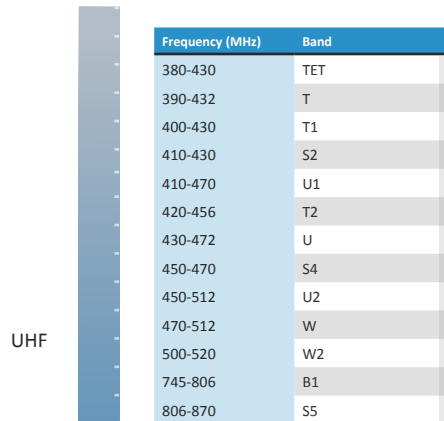
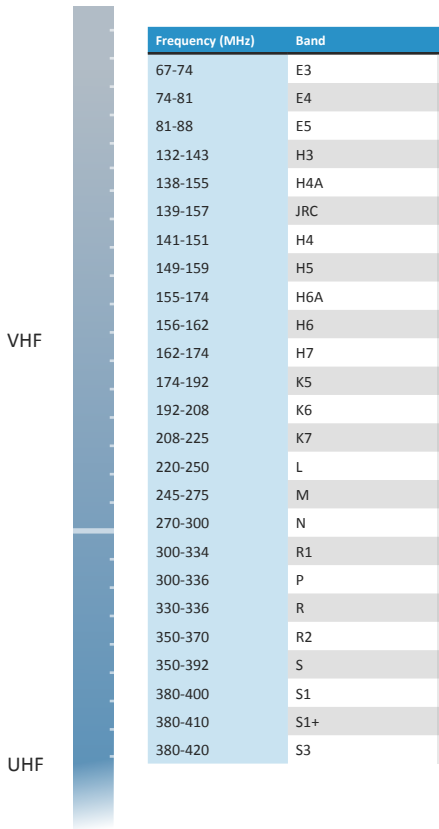

Important Waiver Information

All information and data in this catalogue is intended to provide an indication of the performance of our products under particular circumstances and none of it implies a guarantee of performance or fitness for any particular purpose.

We strongly encourage our customers to conduct their own tests in order to establish the appropriate product for any particular application.

All products should only be installed by a properly qualified installer familiar with appropriate local laws and regulations. We advise our customers to consult and comply with the appropriate Panorama Antennas installation instructions.

All specifications and product information in this catalogue are subject to change without notice.

Designated Names, Trade Marks or other Intellectual Property, not owned by Panorama Antennas is the property of its respective owner(s) and used for identification purposes only.

The Sharkee® is a registered trademark of Panorama Antennas Inc. and may not be reproduced in any form without permission from the original trademark holders.

© 2018 Panorama Antennas Ltd. All Rights Reserved

Global Offices

UK Head Quarters

Panorama Antennas Ltd.

Frogmore
London, SW18 1HF
United Kingdom

T: +44 (0)20 8877 4444
F: +44 (0)20 8877 4477
E: enquiry@panorama-antennas.com
W: www.panorama-antennas.com

Australia & New Zealand

T: +61 1300 859 833
E: au.sales@panorama-antennas.com

Austria, Germany Luxembourg & Switzerland

T: +49 2303 902 88 44
E: de.sales@panorama-antennas.com

France

T: +33 672 540 474
E: fr.sales@panorama-antennas.com

Central & South America

T: +57 1 675 2383
E: sam.sales@panorama-antennas.com

USA & Canada

T: +1 817-539-1888
E: us.sales@panorama-antennas.com

Russia

T: +7 916 137 0646
E: ru.sales@panorama-antennas.com



Panorama Antennas PMR & Public Safety Catalogue

Panorama produces a wide range of tried and trusted antennas for PMR and public safety. Our antennas are used throughout the world by hundreds of public safety departments, NGOs and private users to deliver dependable performance when it is most needed.

Included in this catalogue:

- Multifunction Antennas
- GPS Antennas
- Special Application Antennas
- Cellular Antennas for Mobile Routers
- WiFi Antennas for Mobile Routers
- Covert Antennas
- InBuilding Antennas
- Modular Bases
- Modular Whips
- Combination Base Whips
- Accessories
- Portable Antennas
- Cables & Connectors

PANORAMA  ANTENNAS

Frogmore, London, SW18 1HF
United Kingdom

T: +44 (0)20 8877 4444
F: +44 (0)20 8877 4477

sales@panorama-antennas.com
www.panorama-antennas.com

Dealer Stamp